

OWNER'S MANUAL



Heat Pump Air-To-Air Split Air Conditioner INVERTER CONSOLE NG Series







CH-S09FVX2-NG
CH-S12FVX2-NG
CH-S18FVX2-NG

For proper operation, please read and keep this manual carefully.
Designed by Cooper&Hunter International Corporation, FL Miami, USA

www.cooperandhunter.com

EXPLANATION OF SYMBOLS

 WARNING 	This symbol indicates the possibility of death or serious injury.
 CAUTION 	This symbol indicates the possibility of injury or damage to property.
 NOTICE	Indicates important but not hazard-related information, used to indicate risk of property damage.

EXCEPTION CLAUSES

Manufacturer will bear no responsibilities when personal injury or property loss is caused by the following reasons:





1. Damage the product due to improper use or misuse of the product;
2. Alter, change, maintain or use the product with other equipment without abiding by the instruction manual of manufacturer;
3. After verification, the defect of product is directly caused by corrosive gas;
4. After verification, the defects are due to improper operation during transportation of product;
5. Operate, repair, maintain the unit without abiding by instruction manual or related regulations;
6. After verification, the problem or dispute is caused by the quality specification or performance of parts and components that produced by other manufacturers;
7. The damage is caused by natural calamities, bad using environment or force majeure.

If it needs to install, move or maintain the air conditioner, please contact dealer or local service center to conduct it at first. Air conditioner must be installed, moved or maintained by appointed unit. Otherwise, it may cause serious damage or personal injury or death.

When refrigerant leaks or requires discharge during installation, maintenance, or disassembly, it should be handled by certified professionals or otherwise in compliance with local laws and regulations.

This appliance is not intended for use by persons (including children) with reduced physical, sensory or mental capabilities or lack of experience and knowledge, unless they have been given supervision or instruction concerning the use of the appliance by a person responsible for their safety. Children should be supervised to ensure that they do not play with the appliance.

REFRIGERANT

 <p>Appliance filled with flammable gas R32.</p>	 <p>Before install the appliance, read the installation manual first.</p>
 <p>Before use the appliance, read the owner's manual first.</p>	 <p>Before repair the appliance, read the service manual first.</p>

- To realize the function of the air conditioner unit, a special refrigerant circulates in the system. The used refrigerant is the fluoride R32, which is specially cleaned. The refrigerant is flammable and inodorous. Furthermore, it can lead to explosion under certain conditions. But the flammability of the refrigerant is very low. It can be ignited only by fire.
- Compared to common refrigerants, R32 is a nonpolluting refrigerant with no harm to the ozoneosphere. The influence upon the greenhouse effect is also lower. R32 has got very good thermodynamic features which lead to a really high energy efficiency. The units therefore need a less filling.

 **WARNING** 

Do not use means to accelerate the defrosting process or to clean, other than those recommended by the manufacture. Should repair be necessary, contact your nearest authorized Service Centre. Any repairs carried out by unqualified personnel may be dangerous. The appliance shall be stored in a room without continuously operating ignition sources. (for example: open flames, an operating gas appliance or an operating electric heater.) Do not pierce or burn. Appliance shall be installed, operated and stored in a room with a floor area larger than Xm^2 .

(Please refer to table «a» in section of «Safety operation of flammable refrigerant» for space X.) Appliance filled with flammable gas R32. For repairs, strictly follow manufacturer's instructions only. Be aware that refrigerants may not contain an odor. Read specialist's manual.



This appliance is not intended for use by persons (including children) with reduced physical, sensory or mental capabilities, or lack of experience and knowledge, unless they have been given supervision or instruction concerning use of the appliance by a person responsible for their safety. Children should be supervised to ensure that they do not play with the appliance.

Hereby, Our company, declares that this Air Conditioner is in compliance with the essential requirement and other relevant provisions of RE Directive 2014/53/EU. A copy of the full DoC is attached. Wireless frequency range: 2412MHz – 2472MHz Maximum Transmit Power: 18dBm

R32: 675



This marking indicates that this product should not be disposed with other household wastes.

To prevent possible harm to the environment or human health from uncontrolled waste throughout the EU. To prevent possible harm to the environment or human health.

From uncontrolled waste disposal, recycle it responsibly to promote the sustainable reuse of material resources. To return your used device, please use the return and collection systems or contact the retailer where the product was purchased. They can take this product for environmental safe recycling. If it needs to install, move or maintain the air conditioner, please contact dealer or local service center to conduct it at first. Air conditioner must be installed, moved or maintained by appointed unit. Otherwise, it may cause serious damage or personal injury or death.

SAFETY OPERATION OF FLAMMABLE REFRIGERANT

Qualification requirement for installation and maintenance man

- ▷ All the work men who are engaging in the refrigeration system should bear the valid certification awarded by the authoritative organization and the qualification for dealing with the refrigeration system recognized by this industry. If it needs other technician to maintain and repair the appliance, they should be supervised by the person who bears the qualification for using the flammable refrigerant.
- ▷ It can only be repaired by the method suggested by the equipment's manufacturer.

Installation notes

- ▷ The air conditioner must be installed in a room that is larger than the minimum room area. The minimum room area is shown on the nameplate or following table a.
- ▷ It is not allowed to drill hole or burn the connection pipe.
- ▷ Leak test is a must after installation.

Table A – Minimum room area (m²)

Charge amount (kg)	Floor location	Window mounted	Wall mounted	Ceiling mounted
≤1.2	/	/	/	/
1.3	14.5	5.2	1.6	1.1
1.4	16.8	6.1	1.9	1.3
1.5	19.3	7	2.1	1.4
1.6	22	7.9	2.4	1.6
1.7	24.8	8.9	2.8	1.8
1.8	27.8	10	3.1	2.1
1.9	31	11.2	3.4	2.3
2	34.3	12.4	3.8	2.6
2.1	37.8	13.6	4.2	2.8
2.2	41.5	15	4.6	3.1
2.3	45.4	16.3	5	3.4
2.4	49.4	17.8	5.5	3.7
2.5	53.6	19.3	6	4

Maintenance notes

- ▷ Check whether the maintenance area or the room area meet the requirement of the nameplate.
 - It's only allowed to be operated in the rooms that meet the requirement of the nameplate.
- ▷ Check whether the maintenance area is well-ventilated.
 - The continuous ventilation status should be kept during the operation process.
- ▷ Check whether there is fire source or potential fire source in the maintenance area.
 - The naked flame is prohibited in the maintenance area; and the "no smoking" warning board should be hanged.
- ▷ Check whether the appliance mark is in good condition.
 - Replace the vague or damaged warning mark.

Welding

- ▷ If you should cut or weld the refrigerant system pipes in the process of maintaining, please follow the steps as below:
 - A. Shut down the unit and cut power supply
 - B. Eliminate the refrigerant
 - C. Vacuuming
 - D. Clean it with N₂ gas
 - E. Cutting or welding
 - F. Carry back to the service spot for weldin
- ▷ The refrigerant should be recycled into the specialized storage tank.
- ▷ Make sure that there isn't any naked flame near the outlet of the vacuum pump and it's wellventilated.

Filling the refrigerant

- ▷ Use the refrigerant filling appliances specialized for R32. Make sure that different kinds of refrigerant won't contaminate with each other.
- ▷ The refrigerant tank should be kept upright at the time of filling refrigerant.
- ▷ Stick the label on the system after filling is finished (or haven't finished).
- ▷ Don't overfilling.
- ▷ After filling is finished, please do the leakage detection before test running; another time of leak detection should be done when it's removed.

Safety instructions for transportation and storage

- ▷ Please use the flammable gas detector to check before unload and open the container.
- ▷ No fire source and smoking.
- ▷ According to the local rules and laws.

SAFETY PRECAUTIONS



WARNING



Installation

- ▷ Installation or maintenance must be performed by qualified professionals.
- ▷ The appliance shall be installed in accordance with national wiring regulations. According to the local safety regulations, use qualified power supply circuit and circuit breaker.
- ▷ All wires of indoor unit and outdoor unit should be connected by a professional. Be sure to cut off the power supply before proceeding any work related to electricity and safety.
- ▷ Make sure the power supply matches with the requirement of air conditioner.
- ▷ Unstable power supply or incorrect wiring may result in electric shock, fire hazard or malfunction. Please install proper power supply cables before using the air conditioner.
- ▷ The grounding resistance should comply with national electric safety regulations.

- ▷ Air Conditioner should be properly grounded. Incorrect grounding may cause electric shock.
- ▷ Do not put through the power before finishing installation.
- ▷ Do install the circuit breaker. If not, it may cause malfunction.
- ▷ An all-pole disconnection switch having a contact separation of at least 3mm in all poles should be connected in fixed wiring.
- ▷ Circuit breaker should be included magnet buckle and heating buckle function. It can protect the overload and circuitshort.



CAUTION



- ▷ Instructions for installation and use of this product are provided by the manufacturer.
- ▷ Select a location which is out of reach for children and far away from animals or plants. If it is unavoidable, please add the fence for safety purpose.
- ▷ The indoor unit should be installed close to the wall. Don't use unqualified power cord.
- ▷ If the length of power connection wire is insufficient, please contact the supplier for a new one.
- ▷ The appliance must be positioned so that the plug is accessible.
- ▷ For the air conditioner with plug, the plug should be reachable after finishing installation.
- ▷ For the air conditioner without plug, a circuit breaker must be installed in the line.
- ▷ The yellow-green wire in air conditioner is grounding wire, which can't be used for other purposes. The air conditioner is the first class electric appliance. It must be properly grounded with specialized grounding device by a professional. Please make sure it is always grounded effectively, otherwise it may cause electric shock.
- ▷ The temperature of refrigerant circuit will be high, please keep the interconnection cable away from the copper tube.

SAFETY PRECAUTIONS



WARNING



Operation and Maintenance

- ▷ This appliance can be used by children aged from 8 years and above and persons with reduced physical, sensory or mental capabilities or lack of experience and knowledge if they have been given supervision or instruction concerning use of the appliance in a safe way and understand the hazards involved.
 - ▷ Children shall not play with the appliance.
 - ▷ Cleaning and user maintenance shall not be made by children without supervision.
 - ▷ If the supply cord is damaged, it must be replaced by the manufacturer, its service agent or similarly qualified persons in order to avoid a hazard.
 - ▷ Do not connect air conditioner to multi-purpose socket. Otherwise, it may cause fire hazard.
 - ▷ Do disconnect power supply when cleaning air conditioner. Otherwise, it may cause electric shock. Do not wash the air conditioner with water to avoid electric shock.
 - ▷ Do not spray water on indoor unit. It may cause electric shock or malfunction. Do not repair air conditioner by yourself. It may cause electric shock or damage. Please contact dealer when you need to repair air conditioner.
 - ▷ After removing the filter, do not touch the fins to avoid injury.
 - ▷ Do not extend fingers or objects into air inlet or air outlet. It may cause personal injury or damage.
 - ▷ Do not spill water on the remote controller, otherwise the remote controller may be broken.
 - ▷ Do not use fire or hair dryer to dry the filter to avoid deformation or fire hazard. Do not block air outlet or air inlet. It may cause malfunction.
- ▷ Do not step on top panel of outdoor unit, or put heavy objects. It may cause damage or personal injury. When below phenomenon occurs, please turn off air conditioner and disconnect power immediately, and then contact the dealer or qualified professionals for service:
 - ▷ Power cord is overheating or damaged.
 - ▷ There's abnormal sound during operation.
 - ▷ Circuit breaker trips off frequently.
 - ▷ Air conditioner gives off burning smell.
 - ▷ Indoor unit is leaking.

INSTALLATION NOTICE

Tools for installation

1. Level meter
2. Screw driver
3. Impact drill
4. Drill head
5. Open-end wrench
6. Pipe cutter
7. Leakage detector
8. Universal meter
9. Inner hexagon spanner
10. Measuring tape
11. Pipe expander
12. Torque wrench
13. Vacuum pump
14. Pressure meter



NOTICE

- ▷ Please contact the local agent for installation.
- ▷ Don't use unqualified power cold.

INSTALLATION OF INDOOR UNIT

Selection of installation location.

- ▷ Such a place where cool air can be distributed throughout the room.
- ▷ Such a place where condensation water is easily drained out.
- ▷ Such a place that can handle the weight of indoor unit.
- ▷ Such a place which has easy access for maintenance.
- ▷ The appliance shall not be installed in the laundry.

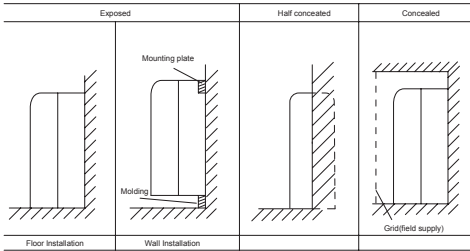

There are 2 styles of installation. Ceiling type Floor type

Each type is similar to the other as follows

The indoor unit should be sited in a place where:

1. The restrictions on installation specified in the indoor unit installation drawings are met.
2. Both air intake and exhaust have clear paths met.
3. The unit is not in the path of direct sunlight.
4. The unit is away from the source of heat or steam.
5. There is no source of machine oil vapour (this may shorten indoor unit life).
6. Cool(warm) air is circulated throughout the room.
7. The unit is away from electronic ignition type fluorwscent lamps as they may shorten the remote controller range.

8. The unit is at least 1 metre away from any television or radio
9. Set (unit may cause interference with the picture or sound).

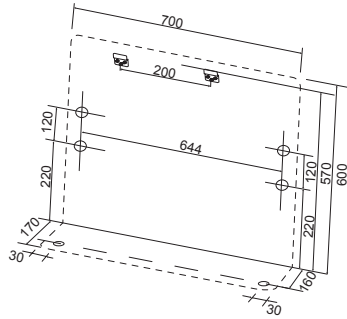

Schematic drawing of hooks:

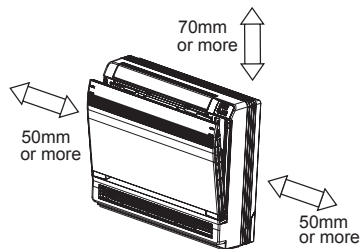
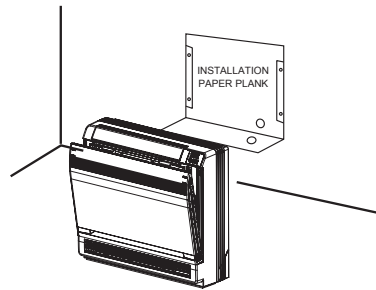

Cautions for installation where air conditioner troubles liable to occur.

- ▷ Where there is too much of oil area.
- ▷ Where it is acid base area.
- ▷ Where there is irregular electrical supply.

INSTALLATION OF INDOOR UNIT

Refrigerant piping

1. Drill a hole (55mm in diameter) in the spot indicated by the symbol  in the illustration as below .
2. The location of the hole is different depending on which side of the pipe is taken out .
3. For piping ,see Connecting the refrigerant pipe ,under Indoor Unit Installation (1).
4. Allow space around the pipe for a easier indoor unit pipe connection.

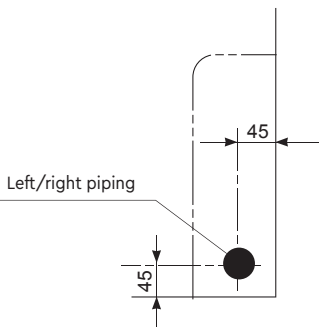
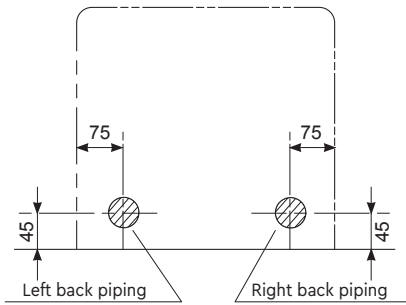
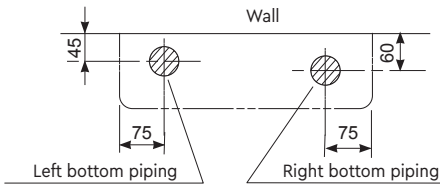

⚠ CAUTION ⚠

Min. allowable length

- ▷ The suggested shortest pipe length is 2.5m, in order to avoid noise from the outdoor unit and vibration. (Mechanical noise and vibration may occur depending on how the unit is installed and the environment in which it is used.)
- ▷ See the installation manual for the outdoor unit for the maximum pipe length.
- ▷ For multi-connections ,see the installation manual for the multi-outdoor unit.

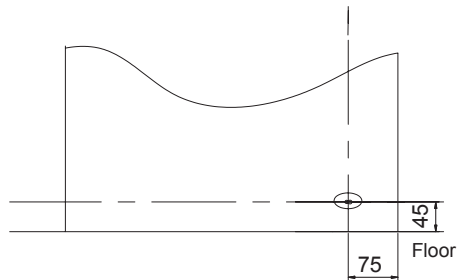
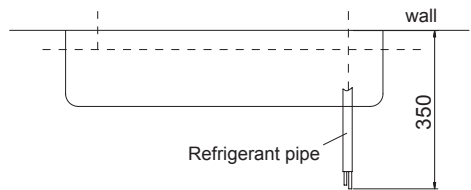

INSTALLATION OF INDOOR UNIT

Boring a wall hole and installing wall embedded pipe

For walls containing metal frame or metal board, be sure to use a wall embedded pipe and wall cover in the feed-through hole to prevent water leakage.

Be sure to caulk the gaps around the pipes with caulking material to prevent water leakage.

1. Bore a feed-through hole of 55mm in the wall so it has a down slope toward the outside.
2. Insert a wall pipe into the hole.
3. Insert a wall cover into wall pipe .
4. After completing refrigerant piping, wiring, and drain piping, caulk pipe hole gap with putty.

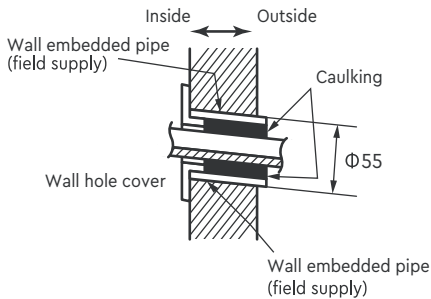

Drain piping

1. Use commercial rigid polyvinyl chloride pipe general VP 20 pipe, outer diameter 26mm, inner diameter 20mm for the drain pipe.
2. The drain hose (outer diameter 18mm at connecting end, 220mm long) is supplied with the indoor unit. Prepare the drain pipe picture below position.
3. The drain pipe should be inclined downward so that water will flow smoothly without any accumulation. (Should not be trap.)
4. Insert the drain hose to this depth so it won't be pulled out of the drain pipe.

5. Insulate the indoor drain pipe with 10mm or more of insulation material to prevent condensation.
6. Remove the air filters and pour some water into the drain pan to check the water flows smoothly.

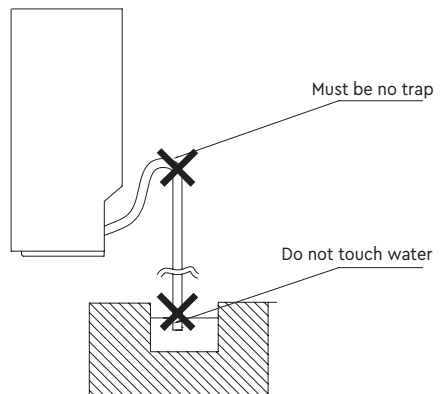
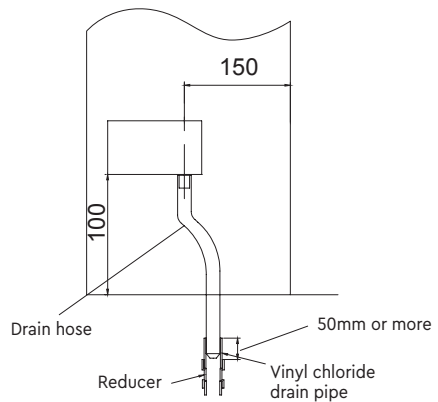
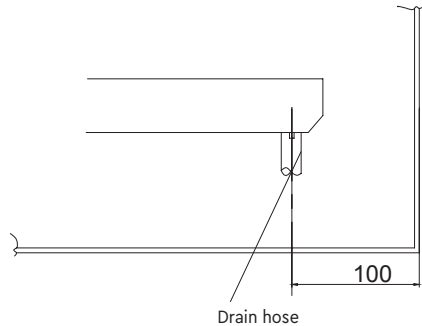

INSTALLATION OF INDOOR UNIT

Preparation

- ▷ Open the front panel, remove the 4 screws and dismount the front grille while pulling it forward.
- ▷ Follow the arrows to disengage the clasps on the front case to remove it.
- ▷ Follow the procedure below when removing the slit portions.

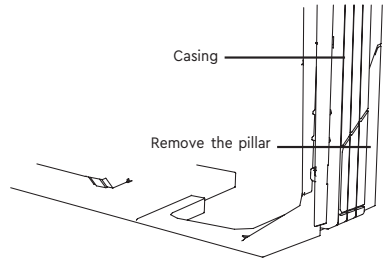
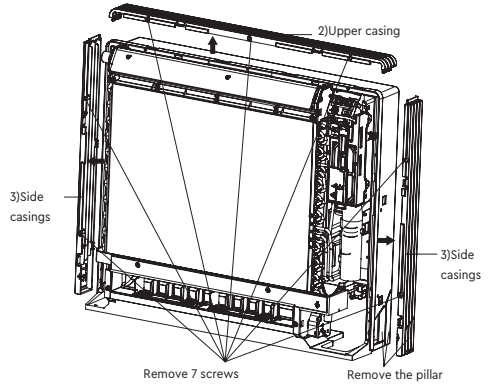
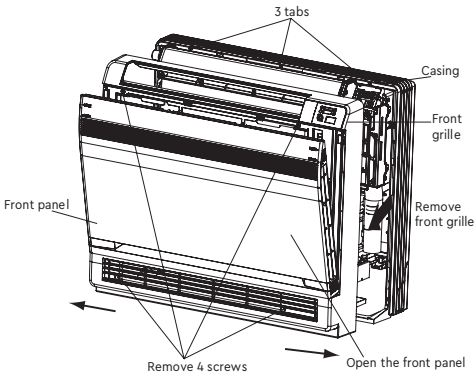

For Moldings

- ▷ Remove the pillars. (Remove the slit portions on the bottom frame using nippers.)

For Side Piping

- ▷ Remove the pillars.
 1. Remove the 7 screws.
 2. Remove the upper casing (2 tabs).
 3. Remove the left and right casings (2 tabs on each side).
 4. Remove the slit portions on the bottom frame and casings using nippers.
 5. Return by following the steps in reverse order(3>2>1).

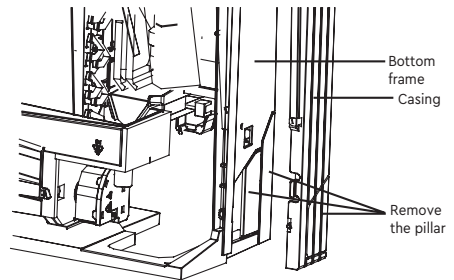

Installation

- ▷ Secure using 6 screws for floor installations. (Do not forget to secure to the rear wall.)
- ▷ For wall installations, secure the mounting plate using 5 screws and the indoor unit using 4 screws.

INSTALLATION OF INDOOR UNIT

The mounting plate should be installed on a wall which can support the weight of the indoor unit.

1. Temporarily secure the mounting plate to the wall, make sure that the panel is completely level, and mark the boring points on the wall.
2. Secure the mounting plate to the wall with screws.

Floor Installation

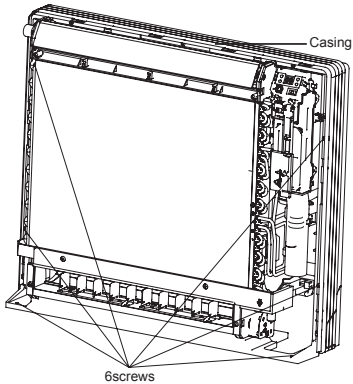

Wall Installation

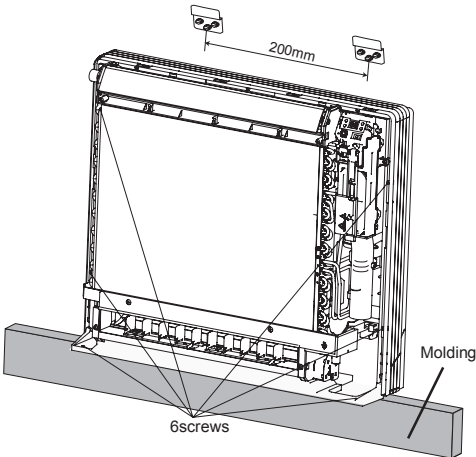

3. Once refrigerant piping and drain piping connections are complete, fill in the gap of the through hole with putty. A gap can lead to condensation on the refrigerant pipe, and drain pipe, and the entry of insects into the pipes.
4. Attach the front panel and front grille in their original positions once all connections are complete.

Flaring the pipe end

1. Cut the pipe end with a pipe cutter.
2. Remove burrs with the cut surface facing downward so that the chips do not enter the pipe.
3. Fit the flare nut on the pipe.
4. Flare the pipe.
5. Check that the flaring is properly made.



WARNING



- ▷ Do not use mineral oil on flared part.
- ▷ Prevent mineral oil from getting into the system as this would reduce the lifetime of the units.
- ▷ Never use piping which had been used for previous installations. Only use parts which are delivered with the unit.
- ▷ Do never install a drier to this R32 unit in order to guarantee its lifetime.
- ▷ The drying material may dissolve and damage the system.
- ▷ Incomplete flaring may cause refrigerant gas leakage.

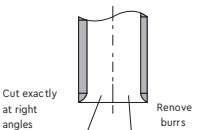

Flaring
Set exactly at the position shown below

Flare tool for R32	Conventional flare tool	
	Clutch-type	Wing-nut type (Imperial-type)
A	0-0.5mm	1.0-1.5mm
		1.5-2.0mm

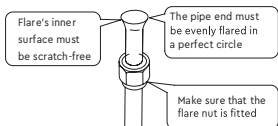

INSTALLATION OF INDOOR UNIT

Connect the pipe of indoor unit

1. Aim the pipe joint at the corresponding bellmouth.
2. Pretighten the union nut with hand.

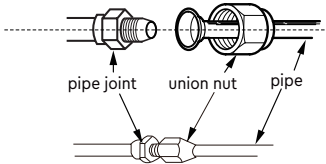

3. Adjust the torque force by referring to the following sheet. Place the open-end wrench on the pipe joint and place the torque wrench on the union nut. Tighten the union nut with torque wrench.

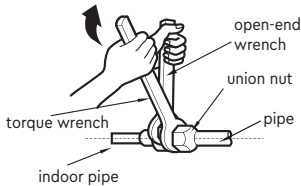

Hex nut diameter	Tightening torque (N.m)
1/4"	15~20
3/8"	30~40
1/2"	45~55

! CAUTION !

1. Protect the open end of the pipe against dust and moisture.
2. All pipe bends should be as gentle as possible. Use a pipe bender for bending. (Bending radius should be 30 to 40mm or larger.)

Selection of copper and heat insulation materials

When using commercial copper pipes and fittings, observe the following:

1. Insulation material: Polyethylene foam
2. Heat transfer rate: 0.041 to 0.052W/mK(0.035 to 0.045kca/(mh°C))
3. Refrigerant gas pipe's surface temperature reaches 110°C max.
4. Choose heat insulation materials that will withstand this temperature.

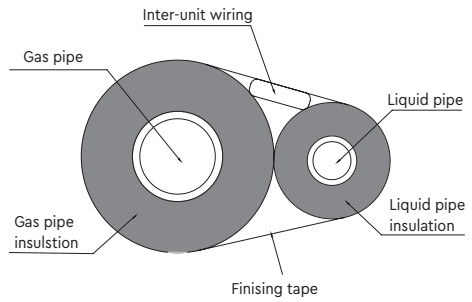

Be sure to insulate both the gas and liquid piping and to provide insulation dimensions as below.

Gas pipe thermal insulation		Liquid pipe thermal insulation
09K/12K	18K	09K-18K
I.D. 12-15mm	I.D. 14-16mm	I.D. 8-10mm
Thickness 10mm Min.		

Use separate thermal insulation pipes for gas and liquid refrigerant pipes.

INSTALLATION OF INDOOR UNIT

Checking for gas leakage

1. Check for leakage of gas after air purging
2. See the sections on air purges and gas leak checks in the installation manual for the outdoor unit.

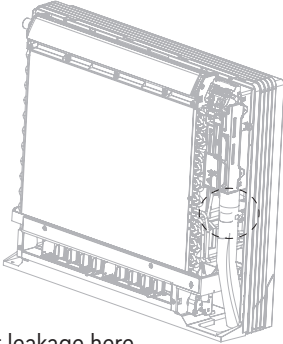

Check for leakage here

- ▷ Apply soapy water and check carefully for leaking gas.
- ▷ wipe soapy water off after the check is complete.

Attaching the connection pipe

Attach the pipe after checking for gas leakage, described above.

1. Cut the insulated portion of the on-site piping, matching it up with the connecting portion.
2. Secure the slit on the refrigerant piping side with the butt joint on the auxiliary piping using the tape, making sure there are no gaps.
3. Wrap the slit and butt joint with the included insulation sheet, making sure there are no gaps.

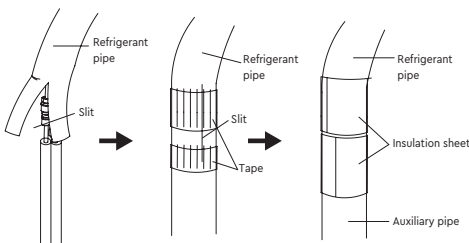

! CAUTION !

1. Insulate the joint of the pipes securely. Incomplete insulation may lead to water leakage.
2. Push the pipe inside so it does not place undue force on the front grille.

Connecting the drain hose

1. Insert the supplied C drain hose into the socket of the drain pan.
2. Fully insert the drain hose until it adheres to a seat of the socket.

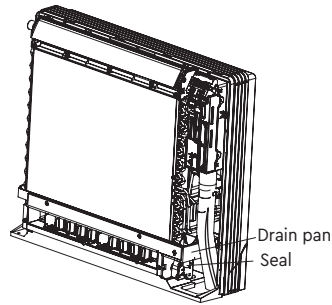
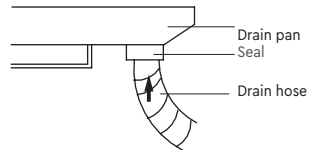

Wiring

Remove the sensor securing plate, remove the front metal plate cover, and connect the branch wiring to the terminal block.

1. Strip wire ends (15mm)
2. Match wire colours with terminal numbers on indoor and outdoor unit's terminal blocks and firmly screw wires to the corresponding terminals.
3. Connect the earth wires to the corresponding terminals.

INSTALLATION OF INDOOR UNIT

4. Pull wires to make sure that they are securely latches up, then retain wires with wire retainer.

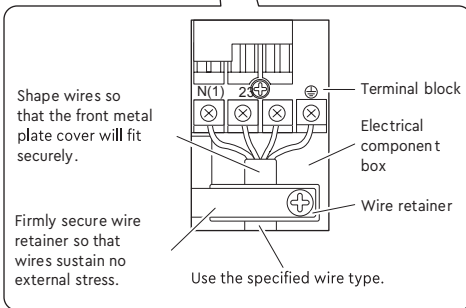
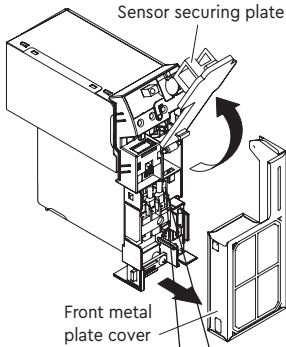

Firmly fix the wires with the terminal screws

When wire length exceeds 10m, use 2.0mm diameter wires

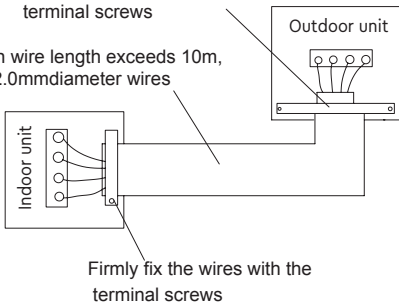

⚠ CAUTION ⚠

1. Do not use tapped wires, stranded wires, extensioncords, or starburst connections, as they may cause overheating, electrical shock, or fire.
2. Do not use locally purchased electrical parts inside the product. (Do not branch the power for the drain pump, etc, from the terminal block.) Doing so may cause electric shock or fire.)

Refrigerant piping work

1. Select copper pipes for gas and liquid as informed in specific table (see the pipe table below)
2. For dust and moisture protection, before assembly of the pipe and its insulation, both end of the pipe must be covered.
3. Avoid pipe bending as much as possible. If it is necessary, the bending radius must be more than 3cm. or 4cm.

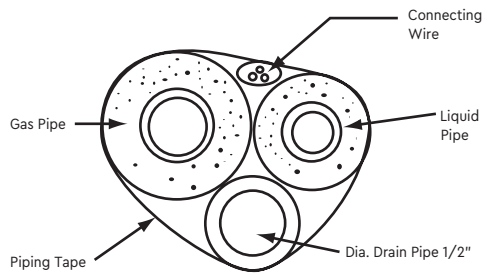

4. The connection between an indoor unit and an outdoor unit.
 - ▷ Unscrew the flare nut for releasing pressure gas in the indoor unit. If there is no high pressure gas blowing out, it is the signal of a leaking indoor unit.
 - ▷ Fit the flare nut to the liquid pipe. Flare the pipe's end with flare tool.
 - ▷ Tighten both flare nuts into gas pipe and liquid pipe at the indoor unit with two holding spanners.

ROUTINE CHECK AFTER INSTALLATION

Check after installation

Items to be checked	Possible malfunction	Situation
Has it been fixed firmly?	The unit may drop, shake or emit noise.	
Have you done the refrigerant leakage test?	It may cause insufficient refrigerating capacity.	
Is heat insulation sufficient?	It may cause condensation and dripping.	
Does the unit drain well?	It may cause condensation and dripping.	
Is the voltage in accordance with the rated voltage marked on the nameplate?	It may cause electric malfunction or damage the part.	
Is the electrical wiring and piping connection installed correctly and securely?	It may cause electric malfunction or damage the part.	
Has the unit been connected to a secure earth connection?	It may cause electrical leakage.	
Is the power cord specified?	It may cause electric malfunction or damage the part.	
Has the inlet and outlet been covered?	It may cause insufficient refrigerating capacity.	
Has the length of connection pipes and the refrigerant charge been record?	The refrigerating capacity is not accurate	
Is the inlet and outlet of piping hole been covered?	It may cause insufficient cooling (heating) capacity or waster eletricity.	

MAINTENANCE



NOTICE

- ▷ Before inspection and maintenance of the unit. PLEASE set power switch to "OFF" to cut off the power supply.

1 Units:

Indoor unit, Outdoor unit and Remote controller

1. Wipe them with dry soft cloth.

Front panel

1. Open the front panel.
 - ▷ Slide the two stoppers on the left and right sides inward until they click.

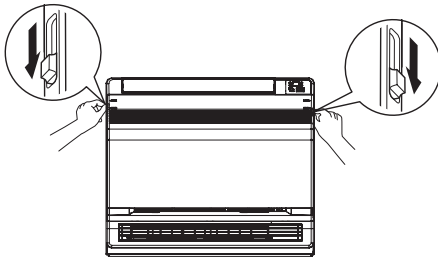

2. Remove the front panel.
 - ▷ Remove the string.
 - ▷ Allowing the front panel to fall forward will enable you to remove it.

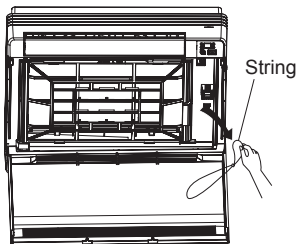

3. Clean the front panel.
 - ▷ Wipe it with a soft cloth soaked in water.
 - ▷ Only neutral detergent may be used.
 - ▷ In case of washing the front panel with water, dry it with cloth, dry it up in the shade after washing.

4. Attach the front panel.
 - ▷ Insert the front panel into the grooves of the unit (3 places).
 - ▷ Attach the string to the right, inner-side of the front grille.
 - ▷ Close the panel slowly.

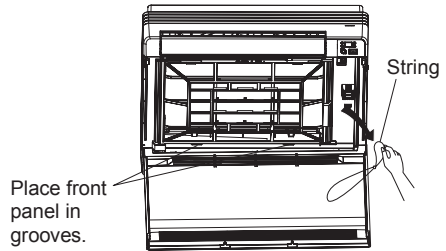

! CAUTION !

- ▷ Don't touch the metal parts of the indoor unit. If you touch those parts, this may cause an injury.
- ▷ When removing or attaching the front panel, use a robust and stable stool and watch your steps carefully.
- ▷ When removing or attaching the front panel, support the panel securely with hand to prevent it from falling.
- ▷ For cleaning, do not use hot water above 40°C, benzene, gasoline, thinner, nor other volatile oils, polishing compound, scrubbing brushes, nor other hand stuff.
- ▷ After cleaning, make sure that the front panel is securely fixed.

MAINTENANCE

2 Filters:

1. Wipe them with dry soft cloth
2. Remove the air filter.
 - ▷ Press the claws on the right and left of the air filter down slightly, then pull upward.
3. Take off the Titanium Apatite Photocatalytic Air-Purifying Filter.
 - ▷ Hold the tabs of the frame, and remove the claws in 4 places.

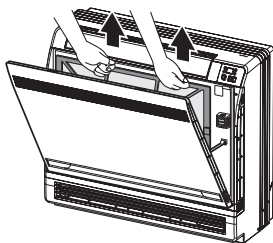

4. Clean or replace each filter.
 - ▷ See figure.

Titanium Apatite
Photocatalytic
Air-Purifying
Filter

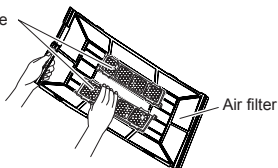

5. Set the air filter and Titanium Apatite Photocatalytic Air-Purifying Filter as they were and close the front panel.
 - ▷ Operation without air filters may result in troubles as dust will accumulate inside the indoor unit.

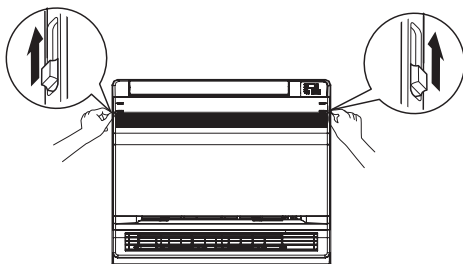

6. Wash the air filters with water or clean them with vacuum cleaner.
 - ▷ If the dust does not come off easily, wash them with neutral detergent thinned with lukewarm water, then dry them up in the shade.
 - ▷ It is recommended to clean the air filters every week.

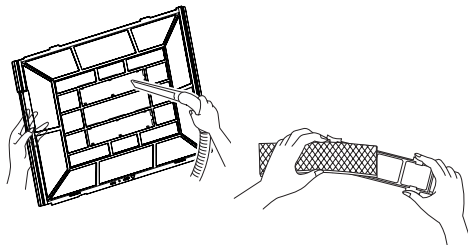

3 Before a long idle period:

1. Operate the "FAN only" for several hours on a fine day to dry out the inside.
 - ▷ Press "MODE" button and select "FAN" operation.
 - ▷ Press "ON/OFF" button and start operation.
2. After operation stops, turn off the breaker for the room air conditioner.
3. Clean the air filters and set them again.
4. Take out batteries from the remote controller.



NOTICE

- ▷ When a multi outdoor unit is connected, make sure the heating operation is not used at the other room before you use the fan operation.

PART NAMES AND THEIR FUNCTIONS



WARNING



▷ Before opening the front panel, be sure to stop the operation and turn the breaker OFF. Do not touch the metal parts on the inside of the indoor unit, as it may result in injury.

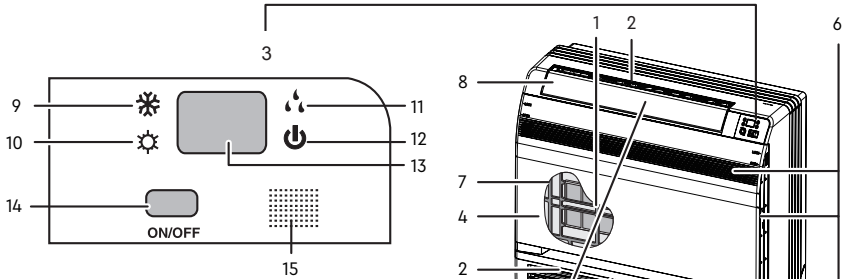

1. Titanium Apatite Photocatalytic Air-Purifying Filter
2. Air outlet
3. Display
4. Front panel
5. Louvers (vertical blades)
6. Air inlet
7. Air filter
8. Flap (horizontal blade)
9. Cool mode lamp
10. Heat mode lamp
11. Dry mode lamp
12. Run lamp
13. LED display
14. Indoor Unit ON/OFF switch
15. Signal receiver
16. Air outlet selection switch
17. Room temperature sensor

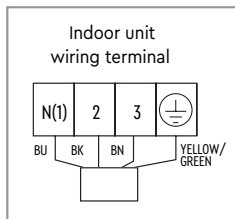
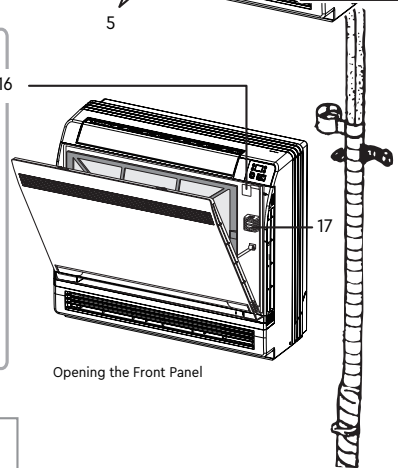
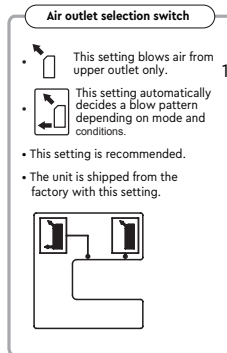

OPERATION AND INTRODUCTION OF REMOTE CONTROLLER



BUTTONS ON REMOTE CONTROLLER

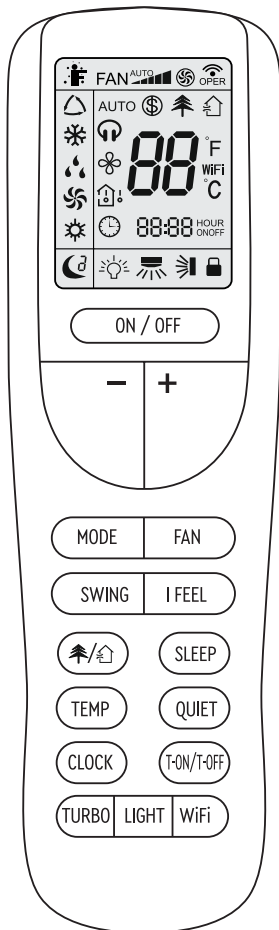

INTRODUCTION FOR ICONS ON DISPLAY SCREEN

FAN	Set fan speed
	Send signal
	X-FAN button
	Set temp.
Temp. display type	Indoor ambient temp.
	Outdoor ambient temp.
Режим робот	Auto mode
	Cool mode
	Dry mode
	Fan mode
	Heat mode
	Set temperature
	8°C heating function
	Heat mode
	Scavenging function
	I Feel
ONOFF	TIMER ON / TIMER OFF
88:88	Set time
WIFI	WiFi function
	Light
	Left & right swing
	Up & down swing
	Child lock
	Turbo mode
	Sleep mode
	Quiet
	Clock

INTRODUCTION FOR BUTTONS ON REMOTE CONTROLLER



NOTICE

▷ This is a general use remote controller, it could be used for the air conditioners with multifunction; For some function, which the model doesn't have, if press the corresponding button on the remote controller that the unit will keep the original running status.

ON / OFF

Button

Press this button to turn on the unit.
Press this button again to turn off the unit.

- Button

Press this button to decrease set temperature. Holding it down above 2 seconds rapidly decreases set temperature. In AUTO mode, set temperature is not adjustable.

+ Button

Press this button to increase set temperature. Holding it down above 2 seconds rapidly increases set temperature. In AUTO mode, set temperature is not adjustable.

MODE

Button

Press this button to select your required operation mode.



▷ After energization, AUTO mode is defaulted. In AUTO mode, the set temperature will not be displayed on the LED of the indoor, and the unit will automatically select the suitable operation mode in accordance with the room temperature to make indoor room comfortable.

FAN

Button

This button is used for setting Fan Speed in the sequence that goes from AUTO, , , , , then back to Auto.

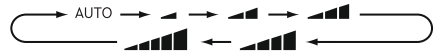

Low speed, Low-Medium speed, Medium speed, Medium-High speed, High speed



NOTICE





- ▷ X-FAN function Hold fan speed button for 2s in cool or dry mode, the icon is displayed and the indoor fan will continue operation for a few minutes in order to dry the indoor unit even though you have turned off the unit. After energization, X-FAN OFF is defaulted. X-FAN is not available in auto, fan or heat mode.
- ▷ This function indicates that moisture on evaporator of indoor unit will be blown after the unit is stopped to avoid mould.
- ▷ Having set X-FAN function on: After turning off the unit by pressing **ON/OFF** button indoor fan will continue running for a few minutes. at low speed. In this period, Hold fan speed button for 2s to stop indoor fan directly.
- ▷ Having set X-FAN function off: After turning off the unit by pressing **ON/OFF** button, the complete unit will be off directly.

SWING

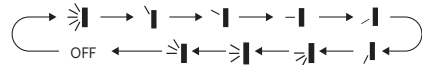
Button

Press this button can select up & down swing angle. Fan blow angle can be selected circularly as below:





- ▷ This remote controller is universal . If any command  is sent out, the unit will carry out the command as .
- ▷  indicates the guide louver swings as: .

Button

Press this button to turn on I FEEL function. The unit automatically adjust temperature according to the sensed temperature. Press this button again to cancel I FEEL function.



When I FEEL function is turned on, the remote controller should be put within the area where indoor unit can receive the signal sent by the remote controller.

Button

Press this button to turn on or turn off the health and scavenging functions in operation status. Press this button for the first time to start scavenging function; LCD displays . Press the button for the second time to start health and scavenging functions simultaneously; LCD displays  and . Press this button for the third time to quit health and scavenging functions simultaneously.

Press the button for the fourth time to start health function; LCD display . Press this button again to repeat the operation above.

Button

Press this button, can select Sleep 1 () , Sleep 2 () , Sleep 3 () and cancel the Sleep, circulate between these, after electrified, Sleep Cancel is defaulted.

- ▷ Sleep 1 is Sleep mode 1, in Cool modes; sleep status after run for one hour, the main unit setting temperature will increase 1 , two hours, setting temperature increased 2 , then the unit will run at this setting temperature; In Heat mode: sleep status after run for one hour, the setting temperature will decrease 1 , two hours, setting temperature will decrease 2 , then the unit will run at this setting temperature.
- ▷ Sleep 2 is sleep mode 2, that is air conditioner will run according to the presetting a group of sleep temperature curve.

- ▷ Sleep 3 – the sleep curve setting under Sleep mode by DIY;

1. Under Sleep 3 mode, press "Turbo" button for a long time, remote controller enters into user individuation sleep setting status, at this time, the time of remote controller will display "1hour ", the setting temperature "88" will display the corresponding temperature of last setting sleep curve and blink (The first entering will display according to the initial curve setting value of original factory);
2. Adjust «▲» a nd «▼» button, could change the corresponding setting temperature, after adjusted, press "Turbo" button for confirmation;
3. At this time, 1hour will be automatically increased at the timer position on the remote control, (that are «2hours» or «3hours» or «8 hours«), the place of setting temperature «88 « will display the corresponding temperature of last setting sleep curve and blink;
4. Repeat the above step (2)~(3) operation, until 8 h ours tempe rature setting fi nished, sleep,curve setting finished, at this time, the remote controller will resume the original timer display; temperature display will resume to original setting temperature.

- ▷ Sleep 3-the sleep curve setting under Sleep mode by DIY could be inquired: The user could accord to sleep curve setting method to inquire the presetting sleep curve, enter into user individuation sleep setting status, but do not change the temperature, press "Turbo" button directly for confirmation.





NOTICE

- ▷ In the above presetting or enquiry procedure, if continuously within 10s, there is no button pressed, the sleep curve setting within 10s, there is no button pressed , the sleep cu rve setting status will be automatically quit and resume to display the original displaying. In the presetting or enquiry procedure, press «ON/OFF» button, «MODE» button, «SLEEP» button, the sleep curve setting or enquiry status will quit similarly.

TEMP Button

Press this button, could select displaying the indoor setting temperature or indoor ambient temperature. When the indoor unit firstly power on it will display the setting temperature, if the temperature's displaying status is changed from other status to , displays the ambient temperature, 5s later or within 5s, it receives other remote control signal that will return to display the setting temperature. if the users haven't set up the temperature displaying status, that will display the setting temperature.

QUIET Button



Press this button, the Quiet status is under the Auto Quiet mode (display «» and «AUTO» signal) and Quiet mode (display «» signal) and Quiet OFF (there is no signal of «» displayed), after powered on, the Quiet OFF is defaulted. fan speed is not available.



NOTICE

▷ Under the Quiet mode (Display «» signal), the fan speed is not available.

CLOCK Button

Press CLOCK button, blinking . Within 5 seconds, pressing «+» or «-» button adjusts the present time. Holding down either button above 2 seconds increases or decreases the time by 1 minute every 0.5 second and then by 10 minutes every 0.5 second. During blinking after setting, press CLOCK button again to confirm the setting, and then  will be constantly displayed.

T-ON/T-OFF Button



Press T-ON button to initiate the auto-ON timer. To cancel the auto-timer program, simply press this button again.

After press of this button,  disappears and «ON» blinks. 00:00 is displayed for ON time setting. Within 5 seconds, press «+» or «-» button on to adjust the time value. Every press of either button changes the time setting by 1 minute. Holding down either button rapidly changes the time setting by 1 minute and then 10 minutes. Within 5 Seconds after setting, press TIMER ON button to confirm. Press T-OFF button to initiate the auto-off timer. To cancel the auto-timer program, simply press the button again. TIMER OFF setting is the same as TIMER ON.

TURBO Button

Press this button to activate / deactivate the TURBO function which enables the unit to reach the preset temperature in the shortest time. In COOL mode, the unit will blow strong cooling air at super high fan speed. In HEAT mode, the unit will blow strong heating air at super high fan speed.

LIGHT Button

Press this button to turn off display light on indoor unit. «» icon on remote controller disappears. Press this button again to turn on display light. «» icon is displayed.

WiFi Button

When WiFi function is turned on, «WiFi» icon will be displayed on the remote controller; when WiFi function is turned off, «WiFi» icon will disappear.

How to turn on WiFi:

Press «WiFi» button to turn on WiFi function.



How to turn off WiFi:

Hold «WiFi» button for 5s to turn off WiFi function.

Under off status, press «MODE» and «WiFi» buttons simultaneously for 1s, WiFi module will restore factory settings.

FUNCTION INTRODUCTION FOR COMBINATION BUTTONS

Child lock function

Press «-» and «+» buttons simultaneously to turn on or turn off child lock function. When child lock function is on, «» icon is displayed on remote controller. If you operate the remote controller, the «» icon will blink three times without sending signal to the unit.

Temperature display switchover function

Under OFF status, press «-» and «MODE» buttons simultaneously to switch temperature display between °C and °F.

Energy-saving function

Under cooling mode, press «TEMP» and «CLOCK» buttons simultaneously to start up or turn off energy-saving function. When energy-saving function is started up, «SE» will be shown on remote controller, and air conditioner will adjust the set temperature automatically according to ex-factory setting to reach to the best energy-saving effect.

Press «TEMP» and «CLOCK» buttons simultaneously again to exit energy-saving function.

8°C heating function

Under heating mode, press «TEMP» and «CLOCK» buttons simultaneously to start up or turn off 8°C heating function. When this function is started up, «» and «8°C» will be shown on remote controller, and the air conditioner keep the heating status at 8°C. Press «TEMP» and «CLOCK» buttons simultaneously again to exit 8°C heating function.

Back-lighting Function

The unit lights for 4s when energizing for the first time, and 3s for later press.

Replacement of batteries in remote controller

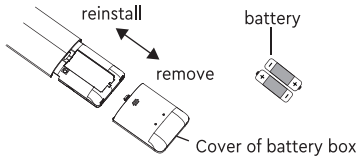

1. Press the back side of remote controller marked with « ≡ », as shown in the fig, and then push out the cover of battery box along the arrow direction.
2. Replace two 7# (AAA 1.5V) dry batteries, and make sure the position of «+» polar and «-» polar are correct.
3. Reinstall the cover of battery box.



NOTICE

- ▷ During operation, point the remote control signal sender at the receiving window on indoor unit.
- ▷ The distance between signal sender and receiving window should be no more than 8m, and there should be no obstacles between them.
- ▷ Signal may be interfered easily in the room where there is fluorescent lamp or wireless telephone; remote controller should be close to indoor unit during operation.
- ▷ Replace new batteries of the same model when replacement is required.
- ▷ When you don't use remote controller for a long time, please take out the batteries.
- ▷ If the display on remote controller is fuzzy or there's no display, please replace batteries.

CONSTRUCTION OF THE OUTDOOR UNIT

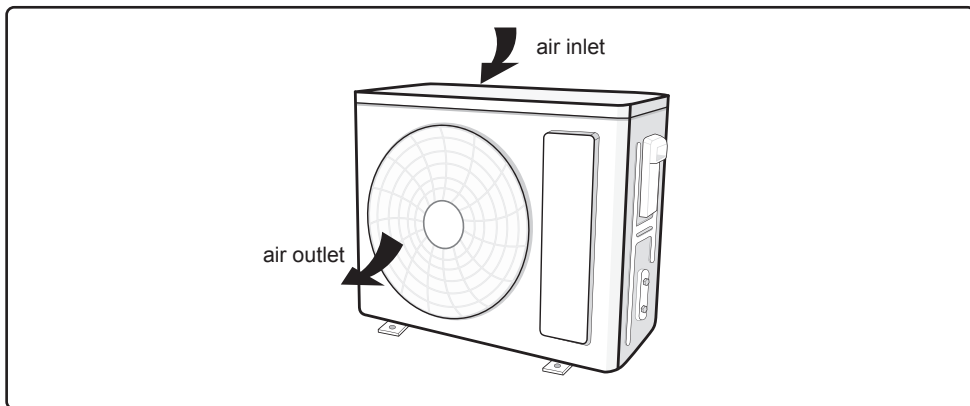

NOTICE

▷ Actual product may be different from above graphics, please refer to actual product.

INSTALLATION NOTICE

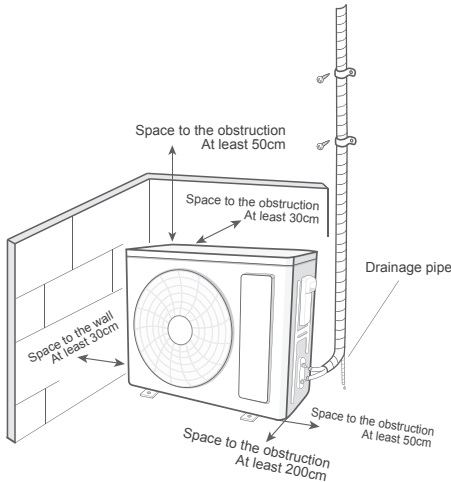

Safety precautions for installing and relocating the unit

To ensure safety, please be mindful of the following precautions.

! CAUTION !

- ▷ **When installing or relocating the unit, be sure to keep the refrigerant circuit free from air or substances other than the specified refrigerant.**

Any presence of air or other foreign substance in the refrigerant circuit will cause system pressure rise or compressor rupture, resulting in injury.

- ▷ **When in stalling or moving this unit, do not charge the refrigerant which is not comply with that on the nameplate or unqualified refrigerant.**

Otherwise, it may cause abnormal operation, wrong action, mechanical malfunction or even serious safety accident.

- ▷ **When refrigerant needs to be recovered during relocating or repairing the unit, be sure that the unit is running in cooling**

! CAUTION !

mode. Then, fully close the valve at high pressure side (liquid valve). About 30-40 seconds later, fully close the valve at low pressure side (gas valve), immediately stop the unit and disconnect power. Please note that the time for refrigerant recovery should not exceed 1 minute.

If refrigerant recovery takes too much time, air may be sucked in and cause pressure rise or compressor rupture, resulting in injury.

- ▷ **During refrigerant recovery, make sure that liquid valve and gas valve are fully closed and power is disconnected before detaching the connection pipe.**

If compressor starts running when stop valve is open and connection pipe is not yet connected, air will be sucked in and cause pressure rise or compressor rupture, resulting in injury.

- ▷ **When installing the unit, make sure that connection pipe is securely connected before the compressor starts running.**

If compressor starts running when stop valve is open and connection pipe is not yet connected, air will be sucked in and cause pressure rise or compressor rupture, resulting in injury.

- ▷ **Prohibit installing the unit at the place where there may be leaked corrosive gas or flammable gas.**

If there is leaked gas around the unit, it may cause explosion and other accidents.

- ▷ **Do not use extension cords for electrical connections. If the electric wire is not long enough, please contact a local service center authorized and ask for a proper electric wire.**

Poor connections may lead to electric shock or fire.

- ▷ **Use the specified types of wires for electrical connections between the indoor and outdoor units. Firmly clamp the wires so that their terminals receive no external stresses.**

Electric wires with insufficient capacity, wrong wire connections and insecure wire terminals may cause electric shock or fire.

INSTALLATION NOTICE

Tools for installation

1. Level meter
2. Screw driver
3. Impact drill
4. Drill head
5. Open-end wrench
6. Pipe cutter
7. Leakage detector
8. Universal meter
9. Inner hexagon spanner
10. Measuring tape
11. Pipe expander
12. Torque wrench
13. Vacuum pump
14. Pressure meter



NOTICE

- ▷ Please contact the local agent for installation.
- ▷ Don't use unqualified power cold.

SELECTION OF INSTALLATION LOCATION

Basic requirement

Installing the unit in the following places may cause malfunction. If it is unavoidable, please consult the local dealer:

1. The place with strong heat sources, vapors, flammable or explosive gas, or volatile objects spread in the air.
2. The place with high-frequency devices (such as welding machine, medical equipment).
3. The place near coast area.
4. The place with oil or fumes in the air.
5. The place with sulfureted gas.
6. Other places with special circumstances.
7. The appliance shall not be installed in the laundry.
8. It's not allowed to be installed on the unstable or motive base structure (such as truck) or in the corrosive environment (such as chemical factory).

Outdoor unit

1. Select a location where the noise and outflow air emitted by the outdoor unit will not affect neighborhood.
2. The location should be well ventilated and dry, in which the outdoor unit won't be exposed directly to sunlight or strong wind.
3. The location should be able to withstand the weight of outdoor unit.
4. Make sure that the installation follows the requirement of installation dimension diagram.
5. Select a location which is out of reach for children and far away from animals or plants. If it is unavoidable, please add the fence for safety purpose.

INSTALLATION NOTICE

Safety precaution

1. Must follow the electric safety regulations when installing the unit.
2. According to the local safety regulations, use qualified power supply circuit and air switch.
3. Make sure the power supply matches with the requirement of air conditioner. Unstable power supply or incorrect wiring or malfunction. Please install proper power supply cables before using the air conditioner.
4. Properly connect the live wire, neutral wire and grounding wire of power socket.
5. Be sure to cut off the power supply before proceeding any work related to electricity and safety.
6. Do not put through the power before finishing installation.
7. If the supply cord is damaged, it must be replaced by the manufacturer, its service agent or similarly qualified persons in order to avoid a hazard.
8. The temperature of refrigerant circuit will be high, please keep the interconnection cable away from the copper tube.
9. The appliance shall be installed in accordance with national wiring regulations.

Grounding requirement

1. The air conditioner is the first class electric appliance. It must be properly grounded with specialized grounding device by a professional. Please make sure it is always grounded effectively, otherwise it may cause electric shock.
2. The yellow-green wire in air conditioner is grounding wire, which can't be used for other purposes.
3. The grounding resistance should comply with national electric safety regulations.
4. The appliance must be positioned so that the plug is accessible.
5. An all-pole disconnection switch having a contact separation of at least 3mm in all poles should be connected in fixed wiring.

Air switch capacity

Including an air switch with suitable capacity, please note the following table. Air switch should be included magnet buckle and heating buckle function, it can protect the circuits short and overload.

(Caution: please do not use the fuse only for protect the circuit)

Air-conditioner	Air switch capacity
09K, 12K	10A
18K	16A
24K	25A

INSTALLATION OF OUTDOOR UNIT

Step 1: Fix the support of outdoor unit

(select it according to the actual installation situation)

1. Select installation location according to the house structure.
2. Fix the support of outdoor unit on the selected location with expansion screws.

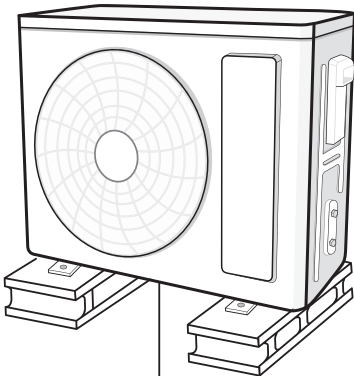

at least 3cm above the floor



NOTICE

- ▷ Take sufficient protective measures when installing the outdoor unit.
- ▷ Make sure the support can withstand at least four times of the unit weight.
- ▷ The outdoor unit should be installed at least 3cm above the floor in order to install drain joint. (for the model with heating tube, the installation height should be no less than 20cm.)
- ▷ For the unit with cooling capacity of 2300 W ~ 5000 W, 6 expansion screws are needed; for the unit with cooling capacity of 6000 W ~ 8000 W, 8 expansion screws are needed; for the unit with cooling capacity of 10000 W ~ 16000 W, 10 expansion screws are needed.

Step 2:

Install drain joint

(only for some models)

1. Connect the outdoor drain joint into the hole on the chassis, as shown in the picture below.
2. Connect the drain hose into the drain vent.



NOTICE

- ▷ As for the shape of drainage joint, please refer to the current product. Do not install the drainage joint in the severe cold area. Otherwise, it will be frosted and then cause malfunction.

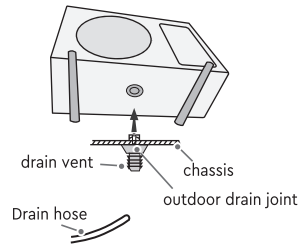

Step 3:

Fix outdoor unit

1. Place the outdoor unit on the support.
2. Fix the foot holes of outdoor unit with bolts.

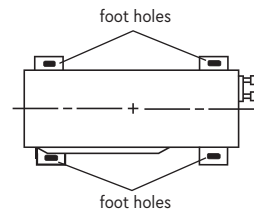

INSTALLATION OF OUTDOOR UNIT

Step 4:

Connect indoor and outdoor pipes

1. Remove the screw on the right handle of outdoor unit and then remove the handle.

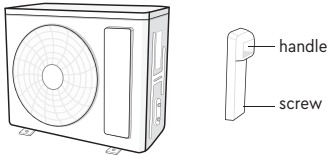

2. Remove the screw cap of valve and aim the pipe joint at the bellmouth of pipe.

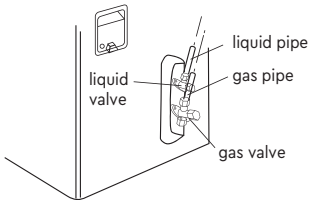

3. Pretighten the union nut with hand.

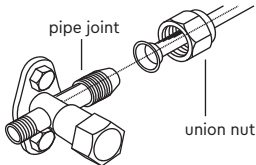

4. Tighten the union nut with torque wrench by referring to the sheet below.

Hex nut diameter	Tightening torque (N m)
1/4"	15~20
3/8"	30~40
1/2"	45~55
5/8"	60~65
3/4"	70~75

Step 5:

Connect outdoor electric wire

1. Remove the wire clip; connect the power connection wire and signal control wire (only for cooling and heating unit) to the wiring terminal according to the color; fix them with screws.

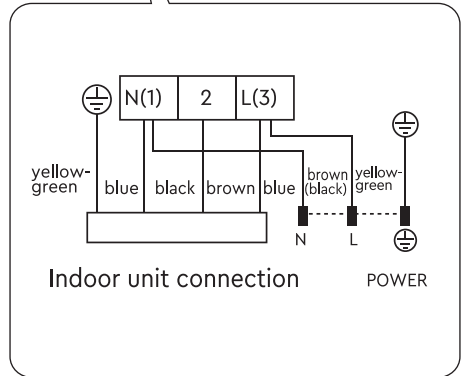
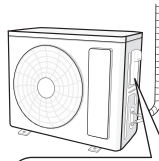

NOTICE

- ▷ The wiring board is for reference only, please refer to the actual one.
2. Fix the power connection wire and signal control wire with wire clip (only for cooling and heating unit).



NOTICE

- ▷ After tighten the screw, pull the power cord slightly to check if it is firm.
- ▷ Never cut the power connection wire to prolong or shorten the distance.

INSTALLATION OF OUTDOOR UNIT

Step 6:

Neaten the pipes

1. The pipes should be placed along the wall, bent reasonably and hidden possibly. Min. semidiameter of bending the pipe is 10cm.
2. If the outdoor unit is higher than the wall hole, you must set a U-shaped curve in the pipe before pipe goes into the room, in order to prevent rain from getting into the room.

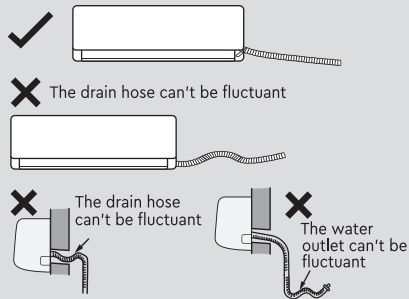
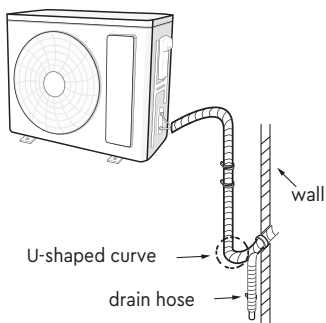

NOTICE

- ▷ The through-wall height of drain hose should not be higher than the outlet pipe hole of indoor unit.

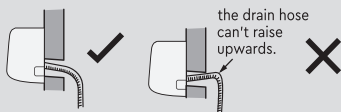

- ▷ The water outlet can't be placed in water in order to drain smoothly.

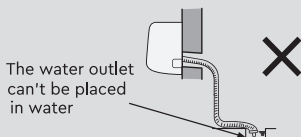

- ▷ Slant the drain hose slightly downwards. The drain hose can't be curved, raised and fluctuant, etc.

TEST AND OPERATION

Use vacuum pump

1. Remove the valve caps on the liquid valve and gas valve and the nut of refrigerant charging vent.
2. Connect the charging hose of piezometer to the refrigerant charging vent of gas valve and then connect the other charging hose to the vacuum pump.
3. Open the piezometer completely and operate for 10–15 min to check if the pressure of piezo- meter remains in -0.1 MPa.
4. Close the vacuum pump and maintain this sta- tus for 1–2 min to check if the pressure of piezometer remains in -0.1 MPa. If the pressure decreases, there may be leakage.
5. Remove the piezometer, open the valve core of liquid valve and gas valve completely with inner hexagon spanner.
6. Tighten the screw caps of valves and refrigerant charging vent.
7. Reinstall the handle.

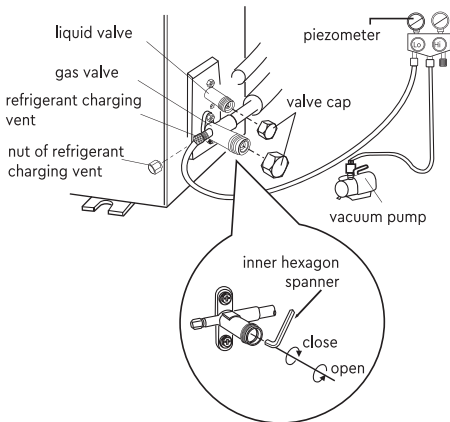

Leakage detection

1. **With leakage detector:** Check if there is leakage with leakage detector.
2. **With soap water:** If leakage detector is not available, please use soap water for leakage detection. Apply soap water at the suspected position and keep the soap water for more than 3min. If there are air bubbles coming out of this position, there's a leakage.

Check after installation

- ▷ Check according to the following requirement after finishing installation.

Items to be checked	Possible malfunction
Has the unit been installed firmly?	The unit may drop, shake or emit noise.
Have you done the refrigerant leakage test?	It may cause insufficient cooling (heating) capacity.
Is heat insulation of pipeline sufficient?	It may cause condensation and water dripping.
Is water drained well?	It may cause condensation and water dripping.
Is the voltage of power supply according to the voltage marked on the nameplate?	It may cause malfunction or damage the parts.
Is electric wiring and pipeline installed correctly?	It may cause malfunction or damage the parts.
Is the unit grounded securely?	It may cause electric leakage.
Does the power cord follow the specification?	It may cause malfunction or damage the parts.
Is there any obstruction in the air inlet and outlet?	It may cause insufficient cooling(heating) capacity.
The dust and sundries caused during installation are removed?	It may cause malfunction or damage the parts.
The gas valve and liquid valve of connection pipe are open completely?	It may cause insufficient cooling (heating) capacity.
Is the inlet and outlet of piping hole been covered?	It may cause insufficient cooling (heating) capacity or waste electricity.

Test operation

1. **Preparation of test operation**

▷ The client approves the air conditioner.

▷ Specify the important notes for air conditioner to the client.
2. **Method of test operation**

▷ Put through the power, press ON/OFF button on the remote controller to start operation.

▷ Press MODE button to select AUTO, COOL, DRY, FAN and HEAT to check whether the operation is normal or not.

▷ If the ambient temperature is lower than 16°C, the air conditioner can't start cooling.

CONFIGURATION OF CONNECTION PIPE

- Standard length of connection pipe: 5 m, 7.5 m, 8 m.
- Min. length of connection pipe.
For the unit with standard connection pipe of 5 m, there is no limitation for the min length of connection pipe. For the unit with standard connection pipe of 7.5 m and 8 m, the min length of connection pipe is 3 m.
- Max. length of connection pipe is shown as below.

Max. length of connection pipe

Cooling capacity	Max. length of connection pipe (m)
5000 Btu/h (1465 W)	15
7000 Btu/h (2051 W)	15
9000 Btu/h (2637 W)	15
12000 Btu/h (3516 W)	20
18000 Btu/h (5274 W)	25
24000 Btu/h (7032 W)	25
28000 Btu/h (8204 W)	30
36000 Btu/h (10548 W)	30
42000 Btu/h (12306 W)	30
48000 Btu/h (14064 W)	30

- The calculation method of additional refrigerant oil and refrigerant charging amount after prolonging connection pipe
After the length of connection pipe is prolonged for 10m at the basis of standard length, you should add 5ml of refrigerant oil for each additional 5m of connection pipe. The calculation method of additional refrigerant charging amount (on the basis of liquid pipe):

(1) Additional refrigerant charging amount = prolonged length of liquid pipe × additional refrigerant charging amount per meter

(2) Basing on the length of standard pipe, add refrigerant according to the requirement as shown in the table. The additional refrigerant charging amount per meter is different according to the diameter of liquid pipe. See Sheet .

Additional refrigerant charging amount for R32

Piping size	Outdoor unit throttle		Indoor unit throttle	Gas pipe	Liquid pipe
	Cooling and heating (g / m)	Cooling only (g / m)			
3/8" or 1/2"	16	12	16	3/8" or 1/2"	1/4"
5/8" or 3/4"	40	12	40	5/8" or 3/4"	1/4" or 3/8"
3/4" or 7/8"	96	24	80	3/4" or 7/8"	1/2"
1" or 1 1/4"	96	48	136	1" or 1 1/4"	5/8"
-	200	200	200	-	3/4"
-	280	280	280	-	7/8"



NOTICE

The additional refrigerant charging amount in Sheet is recommended value, not compulsory.

PIPE EXPANDING METHOD



NOTICE

Improper pipe expanding is the main cause of refrigerant leakage. Please expand the pipe according to the following steps:

A: Cut the pipe

- ▷ Confirm the pipe length according to the distance of indoor unit and outdoor unit.
- ▷ Cut the required pipe with pipe cutter.

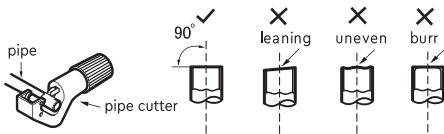

B: Remove the burrs

- ▷ Remove the burrs with shaper and prevent the burrs from getting into the pipe.

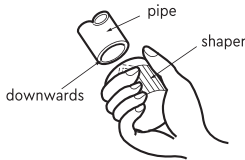

C: Put on suitable insulating pipe

D: Put on the union nut

- ▷ Remove the union nut on the indoor connection pipe and outdoor valve; install the union nut on the pipe.

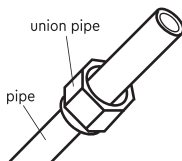

E: Expand the port

- ▷ Expand the port with expander.

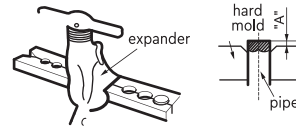

NOTICE

«A» is different according to the diameter, please refer to the sheet below:

Outer diameter (mm)	A (mm)	
	max	min
Ø6 - 6,35 (1/4")	1,3	0,7
Ø9 - 9,52 (3/8")	1,6	1,0
Ø12 - 12,7 (1/2")	1,8	1,0
Ø15,8 - 16 (5/8")	2,4	2,2

F: Inspection

- ▷ Check the quality of expanding port. If there is any blemish, expand the port again according to the steps above.

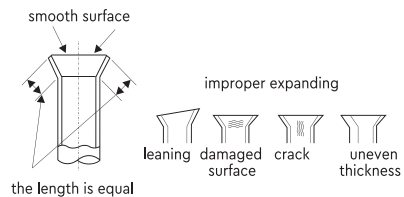

SPECIALIST'S MANUAL

The following checks shall be applied to installations using flammable refrigerants:

- ▷ the charge size is in accordance with the room size within which the refrigerant containing parts are installed;
- ▷ the ventilation machinery and outlets are operating adequately and are not obstructed;
- ▷ if an indirect refrigerating circuit is being used, the secondary circuit shall be checked for the presence of refrigerant;
- ▷ marking to the equipment continues to be visible and legible. Markings and signs that are illegible shall be corrected;
- ▷ refrigeration pipe or components are installed in a position where they are unlikely to be exposed to any substance which may corrode refrigerant containing components, unless the components are constructed of materials which are inherently resistant to being corroded or are suitably protected against being so corroded.

Repair and maintenance to electrical components shall include initial safety checks and component inspection procedures. If a fault exists that could compromise safety, then no electrical supply shall be connected to the circuit until it is satisfactorily dealt with. If the fault cannot be corrected immediately but it is necessary to continue operation, an adequate temporary solution shall be used.

This shall be reported to the owner of the equipment so all parties are advised.

Initial safety checks shall include:

- ▷ that capacitors are discharged: this shall be done in a safe manner to avoid possibility of sparking;
- ▷ that no live electrical components and wiring are exposed while charging, recovering or purging the system;
- ▷ that there is continuity of earth bonding.

Checking for presence of refrigerant

The area shall be checked with an appropriate refrigerant detector prior to and during work, to ensure the technician is aware of potentially toxic or flammable atmospheres. Ensure that the leak detection equipment being used is suitable for use with all applicable refrigerants,

i.e. non-sparking, adequately sealed or intrinsically safe.

Presence of fire extinguisher

If any hot work is to be conducted on the refrigeration equipment or any associated parts, appropriate fire extinguishing equipment shall be available to hand. Have a dry powder or CO₂ fire extinguisher adjacent to the charging area.

Ventilated area

Ensure that the area is in the open or that it is adequately ventilated before breaking into the system or conducting any hot work. A degree of ventilation shall continue during the period that the work is carried out. The ventilation should safely disperse any released refrigerant and preferably expel it externally into the atmosphere.

Checks to the refrigeration equipment

Where electrical components are being changed, they shall be fit for the purpose and to the correct specification. At all times the manufacturer's maintenance and service guidelines shall be followed. If in doubt, consult the manufacturer's technical department for assistance.

Checks to electrical devices

- ▷ that capacitors are discharged: this shall be done in a safe manner to avoid possibility of sparking;
- ▷ that no live electrical components and wiring are exposed while charging, recovering or purging the system.

Repairs to sealed components

During repairs to sealed components, all electrical supplies shall be disconnected from the equipment being worked upon prior to any removal of sealed covers, etc. If it is absolutely necessary to have an electrical supply to equipment during servicing, then a permanently operating form of leak detection shall be located at the most critical point to warn of a potentially hazardous situation.

Particular attention shall be paid to the following to ensure that by working on electrical components, the casing is not altered in such a way that the level of protection is

affected. This shall include damage to cables, excessive number of connections, terminals not made to original specification, damage to seals, incorrect fitting of glands, etc.

- ▷ Ensure that the apparatus is mounted securely.
- ▷ Ensure that seals or sealing materials have not degraded to the point that they no longer serve the purpose of preventing the ingress of flammable atmospheres. Replacement parts shall be in accordance with the manufacturer's specifications.



NOTICE

The use of silicon sealant can inhibit the effectiveness of some types of leak detection equipment. Intrinsically safe components do not have to be isolated prior to working on them.

Repair to intrinsically safe components

Do not apply any permanent inductive or capacitance loads to the circuit without ensuring that this will not exceed the permissible voltage and current permitted for the equipment in use.

Intrinsically safe components are the only types that can be worked on while live in the presence of a flammable atmosphere. The test apparatus shall be at the correct rating.

Replace components only with parts specified by the manufacturer. Other parts may result in the ignition of refrigerant in the atmosphere from a leak.

● Cabling

Check that cabling will not be subject to wear, corrosion, excessive pressure, vibration, sharp edges or any other adverse environmental effects. The check shall also take into account the effects of aging or continual vibration from sources such as compressors or fans.

● Detection of flammable refrigerants

Under no circumstances shall potential sources of ignition be used in the searching for or detection of refrigerant leaks. A halide torch (or any other detector using a naked flame) shall not be used.

● Leak detection methods

Leak detection fluids are suitable for use with most refrigerants but the use of detergents

containing chlorine shall be avoided as the chlorine may react with the refrigerant and corrode the copper pipe-work.

● Decommissioning

Before carrying out this procedure, it is essential that the technician is completely familiar with the equipment and all its detail. It is recommended good practice that all refrigerants are recovered safely. Prior to the task being carried out, an oil and refrigerant sample shall be taken in case analysis is required prior to re-use of reclaimed refrigerant. It is essential that electrical power is available before the task is commenced.

- A. Become familiar with the equipment and its operation.
- B. Isolate system electrically.
- C. Before attempting the procedure, ensure that:
 - ▷ mechanical handling equipment is available, if required, for handling refrigerant cylinders;
 - ▷ all personal protective equipment is available and being used correctly;
 - ▷ the recovery process is supervised at all times by a competent person;
 - ▷ recovery equipment and cylinders conform to the appropriate standards.
- D. Pump down refrigerant system, if possible.
- E. If a vacuum is not possible, make a manifold so that refrigerant can be removed from various parts of the system.
- F. Make sure that cylinder is situated on the scales before recovery takes place.
- G. Start the recovery machine and operate in accordance with manufacturer's instructions.
- H. Do not overfill cylinders. (No more than 80% volume liquid charge).
 - I. Do not exceed the maximum working pressure of the cylinder, even temporarily.
 - J. When the cylinders have been filled correctly and the process completed, make sure that the cylinders and the equipment are removed from site promptly and all isolation valves on the equipment are closed off.
- K. Recovered refrigerant shall not be charged into another refrigeration system unless it has been cleaned and checked.

Labelling

Equipment shall be labelled stating that it has been de-commissioned and emptied of refrigerant. The label shall be dated and signed. For appliances containing flammable refrigerants, ensure that there are labels on the equipment stating the equipment contains flammable refrigerant.

Recovery

When removing refrigerant from a system, either for servicing or decommissioning, it is recommended good practice that all refrigerants are removed safely.

When transferring refrigerant into cylinders, ensure that only appropriate refrigerant recovery cylinders are employed. Ensure that the correct number of cylinders for holding the total system charge are available. All cylinders to be used are designated for the recovered refrigerant and labelled for that refrigerant (i.e. special cylinders for the recovery of refrigerant). Cylinders shall be complete with pressure-relief valve and associated shut-off valves in good working order. Empty recovery cylinders are evacuated and, if possible, cooled before recovery occurs.

The recovery equipment shall be in good working order with a set of instructions concerning the equipment that is at hand and shall be suitable for the recovery of all appropriate refrigerants including, when applicable, flammable refrigerants. In addition, a set of calibrated weighing scales shall be available and in good working order. Hoses shall be complete with leak-free disconnect couplings and in good condition. Before using the recovery machine, check that it is in satisfactory working order, has been properly maintained and that any associated electrical components are sealed to prevent ignition in the event of a refrigerant release. Consult manufacturer if in doubt.

The recovered refrigerant shall be returned to the refrigerant supplier in the correct recovery cylinder, and the relevant waste transfer note arranged. Do not mix refrigerants in recovery units and especially not in cylinders.

If compressors or compressor oils are to be removed, ensure that they have been evacuated to an acceptable level to make certain that

flammable refrigerant does not remain within the lubricant. The evacuation process shall be carried out prior to returning the compressor to the suppliers. Only electric heating to the compressor body shall be employed to accelerate this process. When oil is drained from a system, it shall be carried out safely.

EWPE SMART WI-FI CONTROL APPLICATION

Wi-Fi app and set up

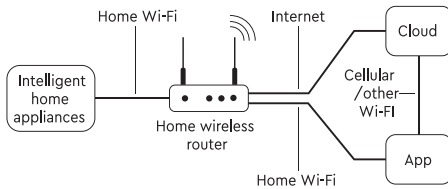

Download and installation

Scan the QR code or search **Ewpe Smart** in the application



market to download and install it. When the application is installed, register the account and add the device to achieve long-distance control and LAN control of smart home appliances.

For more information, please refer to **Help** in app.

Set up process

1. Scan the QR code above with your smart phone to download and install the Wi-Fi application directly.
2. Open the Wi-Fi app and click **Sign up** for registration.
3. Sign in through the prompt interface, you can also enter the homepage and click the profile picture at the left upper corner to sign in.
4. Click + at the right upper corner of homepage to add device and select **AC**.
5. After selecting **AC**, you can select different

Operating systems

Requirement for user's smart phone:



iOS system
Support iOS7.0 and above version



Android system
Support Android 4.4 and above version

reset tools according to actual situation. The app interface will provide relevant operation instructions for different tools.

6. Reset the air conditioner (refer to the operation instructions in app interface) and click Next to add home appliance automatically (Wi-Fi password shall need to be inputted).
7. Or after setting and activating the air conditioner, click **Add appliance manually** at the right upper corner to select the wireless network for controlling the device. Then confirm family Wi-Fi and arrange configuration.
8. After finalising device reset and filling in the correct information, search device and arrange configuration.

Main function settings

In the homepage, click the device in the device list and enter the device into the operation interface.

Set mode, temperature and fan speed to your desired choice.

Advanced settings

Click **FUNC** in the lower left corner in device operation interface to enter advanced settings

Swing Settings

Click **Up down swing** or **Left right swing** to turn on or turn off swing function. Click the arrow at the right lower corner of icon to enter the set swing range.

Preset Setting

Select **Timer** to set preset times of your choice

Other function settings

Homepage menu

Click the profile picture at the left upper corner of homepage and set each function in the following menu.

Scene

Click **Scene** and then you can operate the devices in the preset scene.

Home management

Click **Home management** to create or manage family. You can also add family members according to the registered account.

Help

Click **Help** and view the operation instructions of the app.

SPECIFICATION

Model			CH-S09FVX2-NG	CH-S12FVX2-NG	CH-S18FVX2-NG
Capacity	cooling	kW	2.7	3.52	5.2
	heating	kW	2.9	3.8	5.33
Power supply			~ 220-240V/50Hz/1Ph		
Rated capacity	cooling	kW	0.70	0.926	1.445
	heating	kW	0.73	0.960	1.545
Air flow rate		m ³ /h	500/430/410/370/ 330/280/250	600/520/480/440/ 400/360/280	750/670/600/520/ 470/430/350
Sound level rate	IDU (min/ mid/ max)	db(A)	39/36/34/33/29/26/23	44/40/38/36/33/29/25	49/47/45/42/40/37/32
	ODU	db(A)	51	53	59
Refrigerant type			R32		
Overall dimensions (width/height/ depth)	IDU	mm	700×600×215	700×600×215	700×600×215
	ODU	mm	732×550×330	802×555×350	958×660×402
Weight	IDU	kg	15.5	16.0	16.0
	ODU	kg	24.0	27.5	41.0
Compressor type			Rotary		
Dehumidification		l/h	0.8	1.2	1.8
Temperature range	cooling	°C	-15~43		
	heating		-22~24		
Refrigerant volume system		kg	0.51	0.75	1.00
Liquid line diameter		mm/ inch	6.35/ ¼"	6.35/ ¼"	6.35 / ¼"
Gas line diameter		mm/ inch	9.52/ ⅜"	9.52/ ⅜"	12.7 / ½"
Max. height difference		m	10	10	10
Max. piping length		m	20	20	25



*Cooper&Hunter is constantly working on improvement by pouring their products, so what information given in this manual, may be changed- without prior notice to consumers.

2023/8